

Fresh Water Lobsters in Idaho: Addressing Technical and Economic Barriers for an Emerging Business

Kenneth Neely
Technical Hydrogeologist
Gerry Galinato
Principal Energy Specialist
Idaho Department of Water Resources
September 2005

1. ABSTRACT

Idaho Redclaw Farms, LLC, is an emerging business in Idaho with plans to use geothermal water to raise Australian Redclaw crayfish, also known as fresh water lobsters. Redclaw Farms is located at the Raft River site in southern Cassia County, south-central Idaho, where U.S. Geothermal, Inc., plans to bring a geothermal power plant into operation in 2006. The Redclaw Farms aquaculture operation is currently using a small amount of water that is being “bled” from a future power plant production well. When the power plant starts up, Redclaw Farms will operate downstream of the electrical generation, and will extract heat for its operation using a heat exchanger. As a new startup business, Redclaw Farms faces some challenges related to site engineering and economics. The Idaho Department of Water Resources assisted this developing company through the completion of two technical studies. An engineering study performed by Rafferty (2004) provided options for heat extraction and transfer, building ventilation, and facility layout. An economic feasibility study by Widner and Nelson (2004) indicated that Redclaw Farms would be profitable in both the short and long-term, but that the business is not predicted to generate market rates of return which would provide for cushion in the event that certain identified risks become actual occurrences.

2. PURPOSE AND OBJECTIVES

The purpose of this paper is to describe the steps that Idaho Redclaw Farms, LLC, and the Idaho Department of Water Resources have taken to advance the development of a new geothermal aquaculture business in Idaho. Four specific objectives of this paper are:

1. Describe how Redclaw Farms came into existence, and what it has done to establish a permanent business location.
2. Summarize the results from an engineering study conducted by Kevin Rafferty to assist Redclaw Farms with facility issues.
3. Summarize the results from an economic feasibility study completed by the Lindy Widner and Jim Nelson (University of Idaho) for Redclaw Farms.
4. Discuss the remaining barriers and possible solutions.

3. IDAHO REDCLAW FARMS – THE IDEA, THE BIRTH, AND THE GROWTH

Neil Smeltzer is the visionary, founder, and owner of Idaho Redclaw Farms, LLC. Neil gained experience in the aquaculture industry in California where he worked as the Head of Maintenance and Aeration for Solar Aquafarms, and helped develop the most efficient paddlewheel in the aquaculture industry. During that time, Neil studied the closed looped biofilter system, which is the method that he plans to use in his aquaculture operation. Neil's operation will produce Australian Redclaw crayfish, also known as freshwater lobster, which grow to a length of about 14 inches and produce about one-quarter to one-third pound of edible meat (Figure 1). Using geothermal water to accelerate their growth, Neil plans to have crayfish crops ready for market about nine months after birthing.



Figure 1. Australian Redclaw crayfish are freshwater species whose growth can be accelerated using heat from geothermal water.

Idaho Redclaw began operations with a brood of about 40 crayfish in aquariums at the Smeltzer home in Meridian, Idaho. In 2003, Neil contacted the Idaho Department of Water Resources (IDWR) in search of a warm water location to move his business. Based on an IDWR suggestion, Neil contacted U.S. Geothermal, Inc., which is planning to put a geothermal power plant into operation in Cassia County in south-central Idaho in 2006 (Figure 2). An agreement was reached between Redclaw Farms and U.S. Geothermal in which Redclaw Farms is

to become a cascading geothermal application downstream of the future power plant. Since 2004, when Redclaw Farms arrived at the Raft River location in Cassia County, the brood stock has been reproducing steadily. Neil initially set up the crayfish aquariums and tanks in the living room of his home at Raft River, and then later moved the operation into an existing nearby steel building which now contains six pools for maturing crayfish, and two tanks for breeders (Figure 3). As of May 2005, Redclaw Farms had a couple hundred crayfish in the brood stock, 600-700 maturing individuals, and a couple thousand crayfish babies.



Figure 2. The wide and dry valley floor of Raft River in Cassia County of south-central Idaho is to be the home of Idaho's first geothermal power plant and also the business location of Idaho Redclaw Farms, LLC.

Redclaw Farms may utilize an approach in which groups of five tanks will each have their own dedicated biofilter and heating systems, and will be independent of the other groups of tanks (Figure 4). These individual closed systems will allow Redclaw Farms to carefully control the biological environments within each group of tanks. Water chemistry, nutrient levels, and other parameters can be monitored and treated as necessary. Furthermore, if diseases arise, they can be isolated more easily.

Currently, Redclaw Farms uses a small amount of geothermal water directly from a future power plant production well that is being "bled" for maintenance purposes. This temporary arrangement will change when the power plant comes on line. At that time, Redclaw Farms will operate downstream of the power plant by extracting some of the remaining heat from the used geothermal water before it is re-injected.



Figure 3. Neil Smeltzer (right), owner of Idaho Redclaw Farms LLC, and Bob Shepherd, economic developer for Minidoka and Cassia Counties, discuss Redclaw Farms' plans for raising freshwater lobsters at the Raft River location.

4. AN ENGINEERING STUDY ANSWERS IMPORTANT DESIGN QUESTIONS

In the early development phase of the Redclaw Farm project, it became apparent some engineering evaluation would benefit Neil Smeltzer's plans. The IDWR contracted with Kevin Rafferty to perform a reconnaissance-type study to provide engineering options and cost estimates for the proposed aquaculture operation. Rafferty's work described the following:

1. Geothermal resources to be used for the aquaculture farm
2. Initial facility layout
3. Heating requirements
4. Heating equipment options
5. Annual energy requirements
6. An alternate building envelope

Rafferty's study was based on Redclaw Farms' future plans to use the partially-spent geothermal water downstream from the Raft River power generation facility.

A

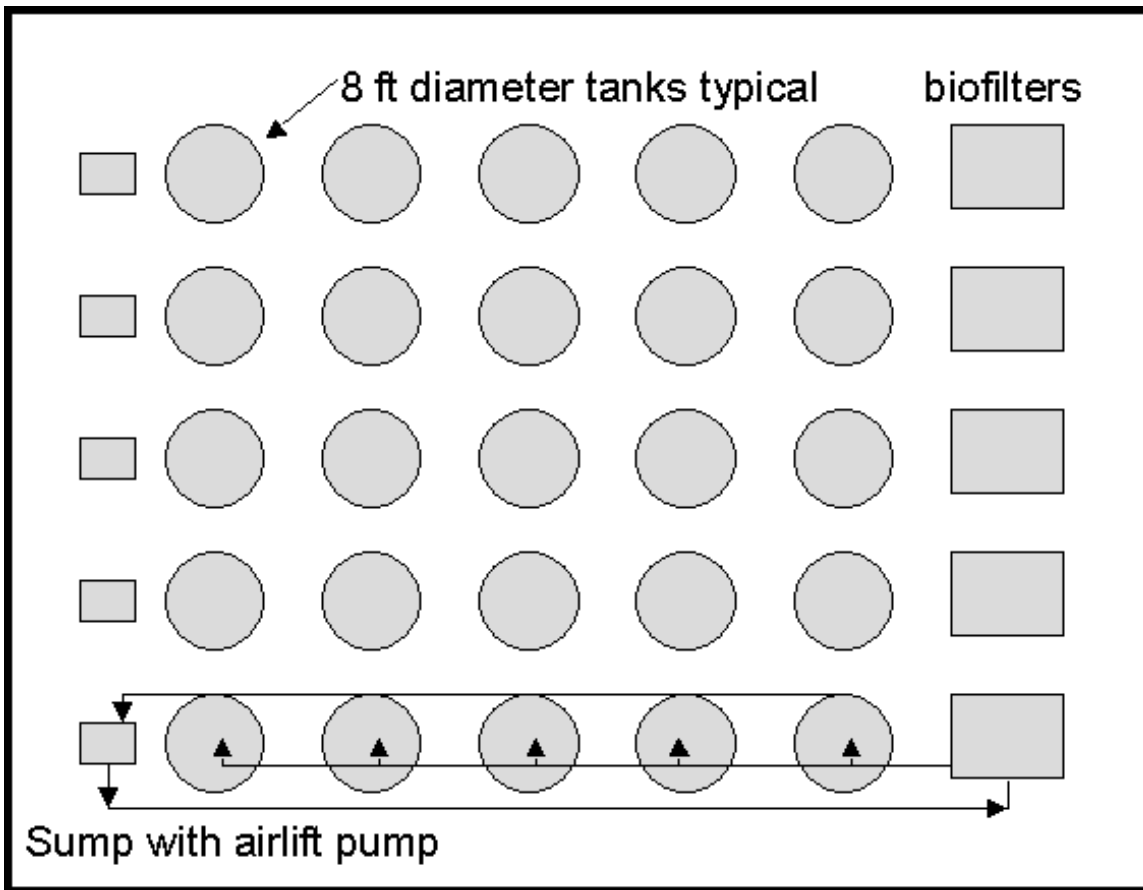

Figure 4. Potential facility layout for the aquaculture operation at Redclaw Farms (from Rafferty, 2004).

concentric pipe heat exchanger system consisting of a three-inch secondary pipe centered inside the six-inch primary line exiting the power facility is to provide the heat required for the aquaculture operations. The water in the primary line would have an incoming temperature of about 240° Fahrenheit (F) and an outgoing temperature after the heat exchange of about 160° F. The three-inch secondary line would be a closed loop system. The 150° F secondary water exiting the heating exchanger would be routed through five heat exchangers for the crayfish tanks, a heat exchanger associated with a loop for heating ventilation air, and at least four unit heaters for maintaining a consistent air temperature in the building. The return temperature of the secondary water would be about 130° F (Figure 5).

Options for housing the crayfish tanks were investigated and discussed in Rafferty's report. The current Redclaw Farms operation is in an existing insulated steel building on the Raft River site. Subsequent expansions are expected to occur in either additional steel buildings, or in greenhouses that are constructed inside steel buildings. The latter approach has several advantages, such as reduced heating requirements because of greater humidity, reduced air ventilation requirements, and reduced or eliminated ventilation preheat requirements. However, this method may have space constraints and construction considerations.

Individual tanks could be heated using heat exchangers submerged in each tank, or by an exterior heat exchanger, which is essentially pipe wrapped around the outside of the tank. A third option would be to make independent sub-systems consisting of five crayfish tanks, a biofiltration system, and a heat exchanger. The third option is presently the top choice for Redclaw Farms.

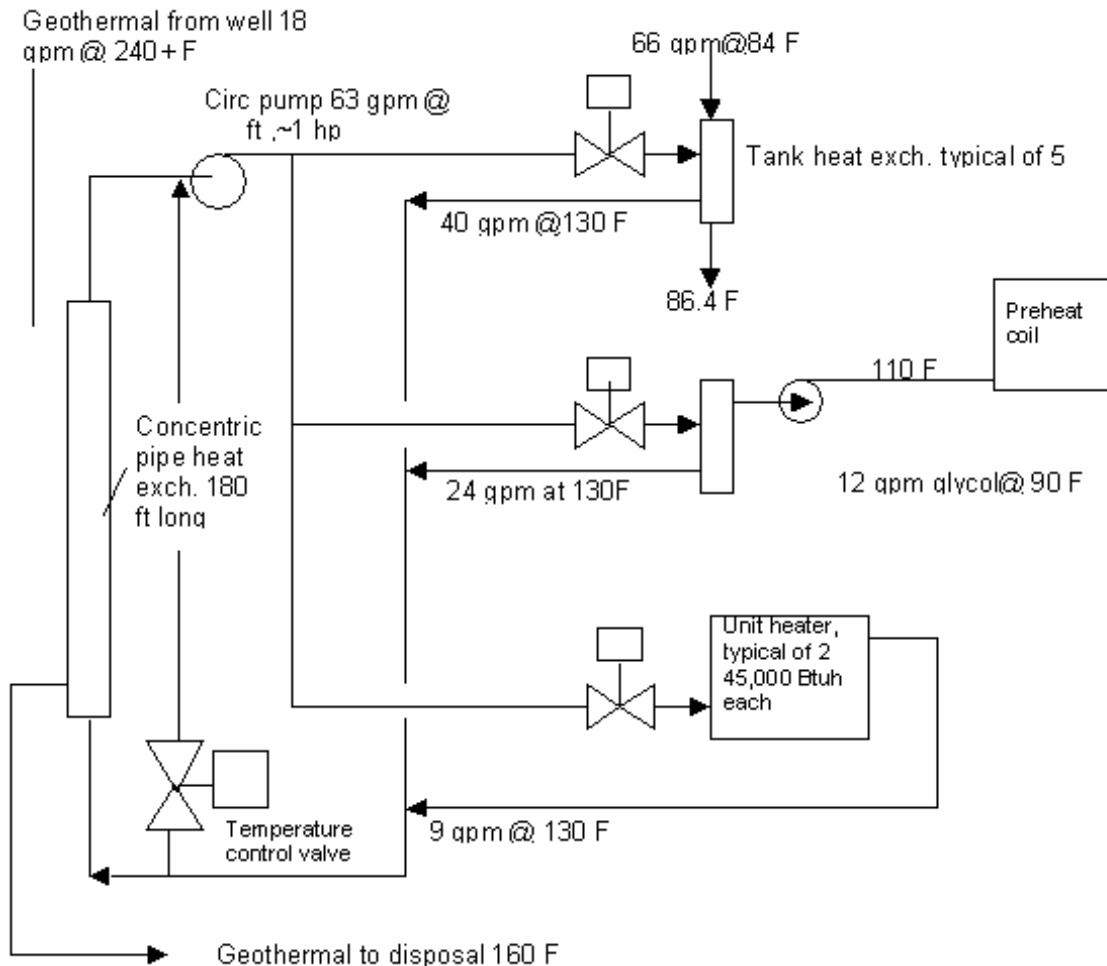

Figure 5. Combined system flow scheme for Idaho Redclaw Farms, LLC. (from Rafferty, 2004).

5. AN ECONOMICS EVALUATION INDICATES THE POTENTIAL FOR FINANCIAL SUCCESS

The University of Idaho, Department of Agricultural Economics and Rural Sociology, completed an economic feasibility study for the proposed Redclaw Farms operation (Widner and Nelson, 2004). The analysis indicated that Redclaw Farms will be “profitable in both the short and long-term and will generate sufficient cash flow to operate.” The analysis was based on the following assumptions:

1. All of the product will be marketable at the price established by Idaho Redclaw Farms, LLC.
2. There will be no native crayfish diseases introduced to the population.
3. Retail value of the crayfish will be \$20 per pound; wholesale price will be \$15 per pound.
4. Each 1000 square feet of production building space will produce 1000 pounds of crayfish, annually.
5. Facility costs will be the same in any new buildings as they will be for the initial 2500 square foot described in Rafferty's (2004) engineering study.
6. An investment rate of 10 percent was used.
7. The life of the investment will be 10 years.

Although the analysis yielded a favorable economic future for Redclaw Farms, there are some significant concerns that need to be addressed. For example, research has not yet been completed to determine the volume and price that the markets will bear. A recall plan needs to be put into place in the case of a contaminated product, and insurance should be obtained in order to protect the investments. Lindy and Nelson (2004) recommended a completed business plan as an excellent tool for addressing management and marketing issues, and for acquiring financial resources from lending institutions. And finally, the business is not predicted to generate market rates of return which would provide for cushion in the event that certain identified risks (such as a disease outbreak) become actual occurrences.

6. BARRIERS AND POSSIBLE SOLUTIONS

Several existing barriers must be overcome in order for Neil Smeltzer to achieve his goals for Redclaw Farms.

1. Currently, Redclaw Farms needs to secure financing that will allow it to proceed with development plans. Redclaw is negotiating with U.S. Geothermal to secure ownership on a piece of the land at the Raft River location which will potentially open up more investment opportunities through banking institutions, and other entities or individuals.
2. The facility design must be finalized according to the business objectives and the economics. This probably should be done before lending institutions are approached. Designs presented by Rafferty (2004) will be helpful in developing the site plans. After finances are secured, construction can begin.
3. Marketing plans must be completed in order to ensure that financial objectives are met. Redclaw Farms has an arrangement with another Idaho aquaculture operation to deliver ½ of its products to the Seattle area. The other ½ of the product may be sold in Idaho.

Idaho Redclaw Farms, LLC, and U.S. Geothermal, Inc, are using their entrepreneurial spirits and ingenuities in utilizing a geothermal resource in south-central Idaho for two very different applications. Hopefully, in the not-so-distant future, both electrons and

fresh water lobsters will be leaving the Raft River location as two new operations are successfully launched.

7. REFERENCES

Rafferty, K.D., 2004. "Freshwater Aquaculture Geothermal Feasibility Study: Raft River, ID." Prepared for the Idaho Department of Water Resources Energy Division, 27 p.

Widner, L., and J.R. Nelson, 2004. "Economic Feasibility of a Proposed Redclaw Crayfish Farm Utilizing Geothermal Water as an Energy Resource." University of Idaho College of Agricultural and Life Sciences, 23 p.